



Blower Purge Regenerative

PB Series Air/Gas Dryers



Blower Purge (PB Series)

Advantages

- Performance of -10°F to -40°F pressure dew point with only slight dew point spikes at tower switch-over
- No compressed air lost during purging
- Minimal air loss during polishing cycle (dry air sweep) to minimize dew point spike (can be operated with no polishing cycle)
- Minimal pressure drop – less than 3 PSID
- Reduces operational downtime
- Gradual pressurization prevents pressure surges and desiccant bed attrition
- Quiet and reliable operation

PB Series Flow Diagram

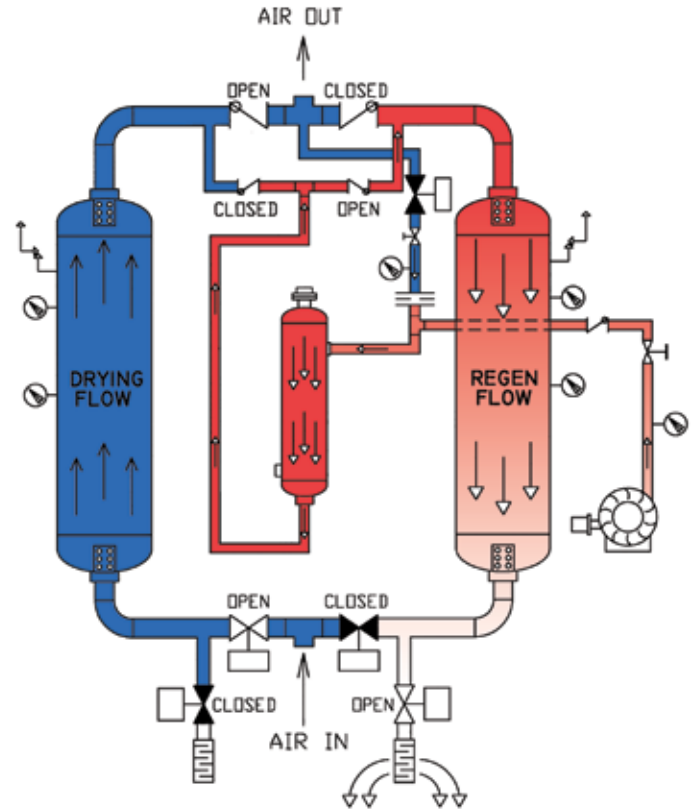

Here's How It Works

Pneumatech's Blower Purge Regenerative Dryer (PB Series) delivers superior performance and durability. Along with exceptional drying power, Pneumatech's Blower Purge dryer adds extra value to your operation by conserving compressed air and extending desiccant life.

Fully Automatic Operation

Fully automatic with a standard eight-hour cycle — four hours of drying time and four hours of regeneration time — the PB Series' two-tower configuration ensures an uninterrupted supply of dry air.

The PB Series uses ambient air to heat the regenerating tower and desorb the desiccant. Ambient air is pulled through an intake filter and into the heater chamber by a blower, and heated to approximately 400°F . Air then

passes uniformly through the regenerating tower, where the moisture is desorbed before the air purges into the atmosphere. The heater is turned off after a period of time and the cooling cycle is initiated with ambient air. After a short period, the blower is de-energized and the cooling cycle continues using a 50-minute dry-air sweep for final polishing and to reduce the dew point spike at tower switch-over. At the end of the cycle, the tower is repressurized with dry air and is ready for switching.

Features

- Allen-Bradley MicroLogix 1000 PLC for trouble free operation.
- Thermostat-controlled, low-watt density heater prevents excessive temperatures, extending heater life.
- Removable inlet and outlet stainless screens designed for proper air diffusion and desiccant retention.
- High performance, wafer-style butterfly valves are non-proprietary and commercially available.
- Cool down cycle to minimize high temperature air discharge.
- Polishing cycle (dry-air sweep) for consistent dew point performance.
- High-capacity heating chamber maximizes heat load for regeneration.
- Heater temperature-control thermostat and desiccant bed thermostats for full dryer protection.
- Purge line return check-valves are equipped with stainless steel springs and Viton seats to withstand excessive heat and eliminate chattering.
- Centrifugal, multi-stage blower with intake filter protects the blower and desiccant beds from particles.



Centrifugal, multi-stage blower

Options

Dew Point Demand (DPD)

Pneumatech's Dew Point Demand control system reduces energy consumption by automatically regulating purge in response to actual moisture load. The DPD senses the dew point of the outlet air and delays tower switching until the drying bed is saturated to the preset dew point level.

Benefits:

- Purge flow and heater on time are significantly reduced.
- Superior energy savings.
- Extended dryer life.



Dew Point display



Sensor

Alarms

Pneumatech alarms use readily visible warning lights— or optional high-decibel buzzers— to alert operators when dryers are not functioning properly. Dry contacts are provided for remote annunciation.

FAILURE TO SHIFT: Alerts operator if the desiccant towers fail to shift at a prescribed time.

HIGH HUMIDITY: Alerts operator when the dew point reaches +10°F and above. A small amount of sample air is required for operation.

HEATER FAILURE: Alerts operator if the heater fails to reach the designated temperature during regeneration.

Special Electrical

UL & CUL Control Panel, NEMA 7 & 9, NEMA 4X.

Panel Mounted Sequence Lights

Indicate Left/Right tower drying, Left/Right tower regenerating.

Moisture Indicator

Samples outlet air and changes color as dew point rises.

Dryer Mode Switch

Allows switching to external heat mode (7% purge) in case of blower failure.

PLC Upgrade

Customer brand PLC is specified. Contact factory for pricing. Allen-Bradley MicroLogix 1000 is standard.

Filter Mounting and Bypass

Pre and After filters mounted. Dryer and filter bypass available.

External Steam Heater

A steam heat exchanger can be used in place of a standard electric heater. It is manufactured with a carbon steel shell and stainless steel tubes. The steam heater is fitted with expansion joints to avoid thermal shock failures. Steam requirement: 350°F (Min) saturated steam @ 135 PSIG.

Specifications

MODEL*	RATED CAP. SCFM (NM ³ / HR)	HEATER KW	BLOWER H.P.	CONN. IN / OUT	DESICCANT LBS. (KGS.) PER TOWER	DIMENSIONS INCHES (MILLIMETERS) L x W x H	APPROX. SHIP WT. LBS. (KGS.)
PB-350	350 (849.6)	9	4	2" NPT	280 (127)	63 x 46 x 86 (1,600 x 1,168 x 2,184)	1,525 (692)
PB-400	400 (849.6)	9	4	2" NPT	300 (136)	65 x 48 x 88 (1,651 x 1,219 x 2,235)	1,550 (703)
PB-500	500 (849.6)	12.5	5	2" NPT	375 (170.1)	74 x 50 x 101 (1,880 x 1,270 x 2,565)	2,500 (1,135)
PB-650	650 (1,104.5)	15	5	2" NPT	490 (222.3)	74 x 46 x 101 (1,880 x 1,168 x 2,565)	3,450 (1,565)
PB-750	750 (1,274.4)	18	5	2.5" FLG	570 (258.6)	80 x 56 x 96 (2,032 x 1,422 x 2,438)	3,850 (1,750)
PB-1000	1,000 (1,699.2)	24	7.5	2.5" FLG	750 (340.2)	90 x 66 x 108 (2,286 x 1,676 x 2,743)	4,450 (2,015)
PB-1250	1,250 (2,124.0)	27	7.5	3" FLG	950 (430.9)	97 x 68 x 96 (2,464 x 1,727 x 2,438)	5,200 (2,360)
PB-1500	1,500 (2,548.8)	30	10	3" FLG	1,125 (510.3)	97 x 68 x 110 (2,464 x 1,727 x 2,794)	5,525 (2,510)
PB-1800	1,800 (3,058.6)	40	10	4" FLG	1,350 (612.4)	112 x 82 x 108 (2,845 x 2,083 x 2,743)	6,700 (3,040)
PB-2100	2,100 (3,568.3)	50	15	4" FLG	1,575 (714.4)	142 x 72 x 130 (3,607 x 1,829 x 3,302)	9,100 (4,130)
PB-2600	2,600 (4,417.9)	65	15	4" FLG	1,950 (884.5)	160 x 86 x 114 (4,064 x 2,184 x 2,896)	10,600 (4,810)
PB-3100	3,100 (5,267.5)	80	20	6" FLG	2,325 (1,054.6)	170 x 90 x 126 (4,318 x 2,286 x 3,200)	11,850 (5,375)

Operating Specifications

Operating Pressure: 100 PSIG
 Operating Temp: 100° F
 Design Pressure: 150 PSIG at 450° F (Vessels)
 Outlet Dew Point: -10° F to -40° F
 Power Supply: 460V – 3PH – 60HZ
 Electricals: NEMA 4
 NEMA Cycle: 8 Hours
 Desiccant: Activated Alumina

* Model number indicates rated capacity @ 100°F inlet, 100°F ambient and 100 PSIG. Maximum design pressure is 150 PSIG.

- NEMA-4 electrical enclosure with externally mounted On/Off switch, Power On light, Blower On light, Heater On light and Low Pressure Warning light.
- All dryer models use non-lubricated, wafer-style, ductile iron butterfly valves with Viton seats.

Pneumatech reserves the right to change or revise specifications and product design in connection with any features of our products. Such changes do not entitle the buyer to corresponding changes, improvements, additions or replacements for equipment previously sold or shipped.

Distributed by:

PNEUMATECH^{INC.}
& ConservAIR[®] Technologies Co. LLP

4909 70th Avenue • Kenosha, Wisconsin U.S.A. 53144
 (262) 658-4300 Fax: (262) 658-1945 • www.pneumatech.com

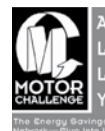

Use of this Motor Challenge logo does not imply DOE endorsement.